

WORLD MARKET®

Assembly Instructions

NOELLE SHELTER ARM SOFA

SKU 550025&562757

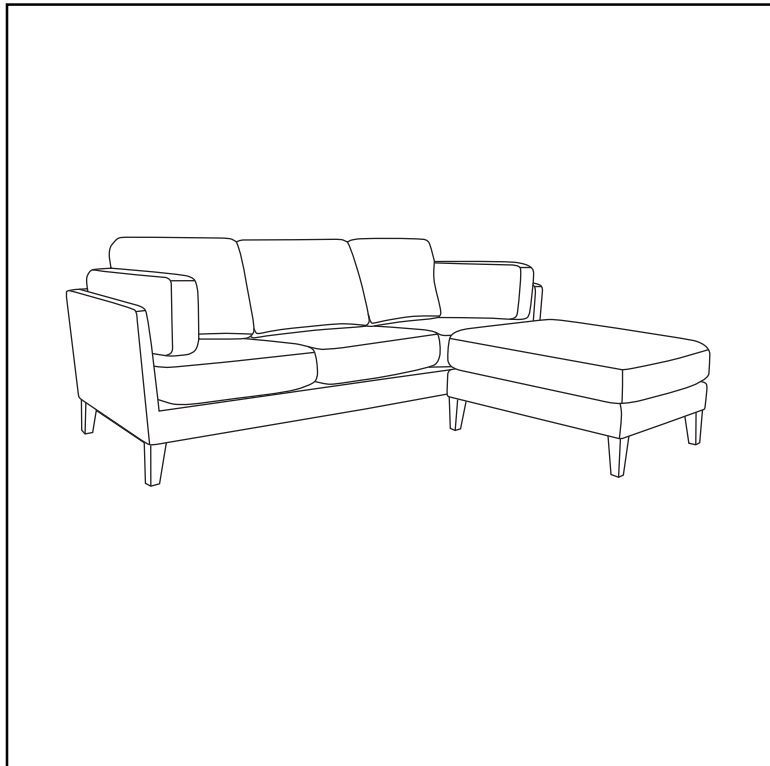



THANK YOU FOR PURCHASING OUR QUALITY PRODUCT. IF YOU HAVE ANY QUESTIONS PERTAINING TO THE ASSEMBLY OF THIS FURNITURE PIECE, PLEASE CONTACT YOUR NEAREST WORLD MARKET STORE. IF YOU ARE NOT NEAR A STORE, PLEASE CALL OUR CUSTOMER SERVICE CALL CENTER TOLL FREE AT 877-967-5362 FOR ASSISTANCE.

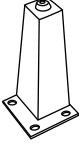

ALL PRODUCTS SOLD AT WORLD MARKET ARE NOT FOR COMMERCIAL USE AND ARE INTENDED FOR RESIDENTIAL USE ONLY

Page 1

Parts List

Label	Picture	Description	Qty
A		Leg	8
B		Mid Leg	1

Hardware List

Label	Picture	Description	Qty
H-1		Allen Bolt (5/16" x 30mm)	24
H-2		Spring Washer	24
H-3		Flat Washer	24

Tool List

Label	Picture	Description	Qty
T-1		Allen Key	1

Assembly Preparation

Before Beginning:

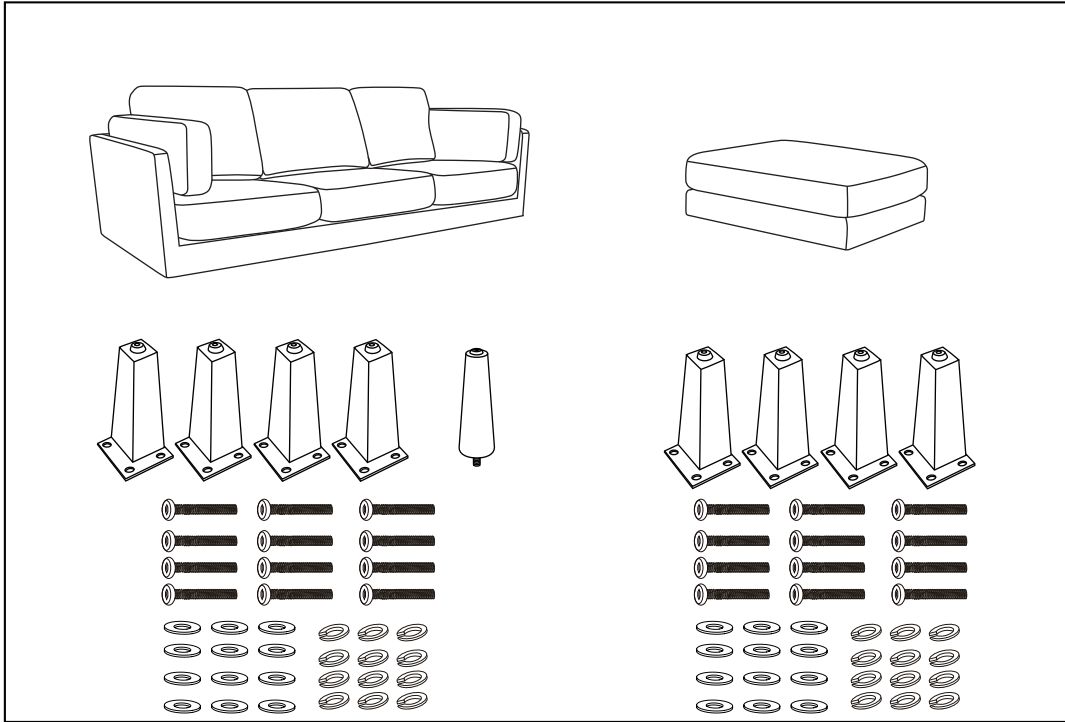

- Read instructions, cover to cover.



- Have 2 adults on hand for assembly.



- Do not assemble on flooring or carpet.



- Assemble on a clean non-marring surface.



- Save all packaging until finished.



- In case of missing parts, please contact your nearest World Market store or call our customer service call center at call 1-877-967-5362.

Assembly Steps

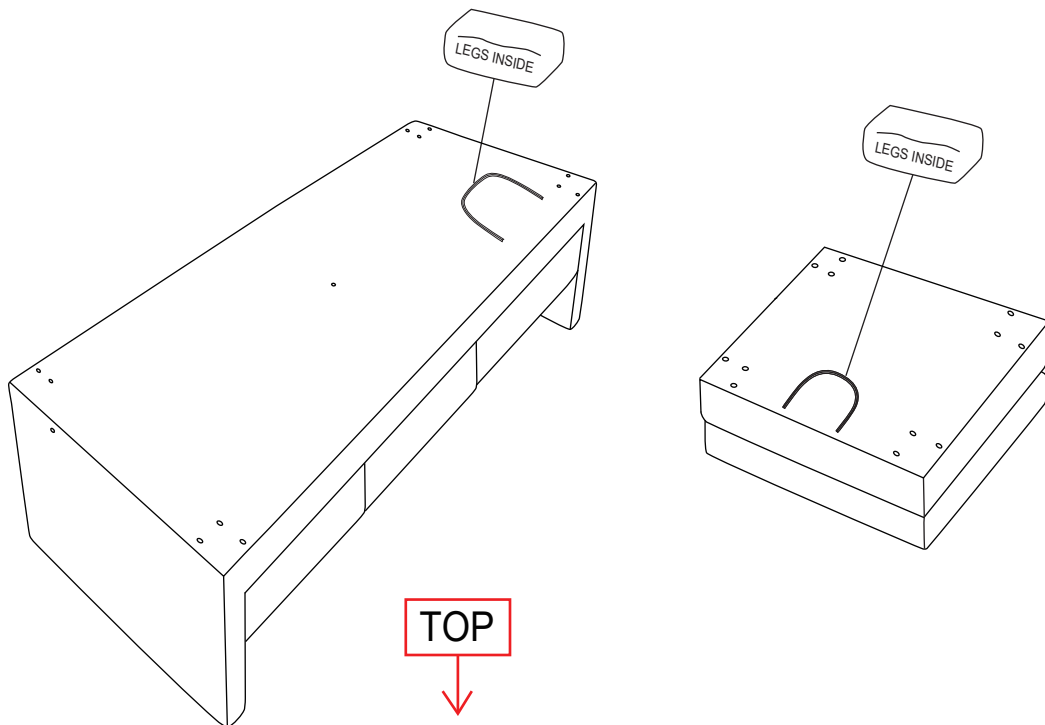

Step 1



Using a second person to assist you, turn the sofa and ottoman assemblies upside down onto a padded, non-marring surface. On the bottom of each assembly, open up the zipper compartment and remove the leg hardware packaging. Close the zipper compartments once the packages have been removed.

Assembly Steps

Step 2

-  (H-1) Allen Bolt x 24
-  (H-2) Spring Washer x 24
-  (H-3) Flat Washer x 24

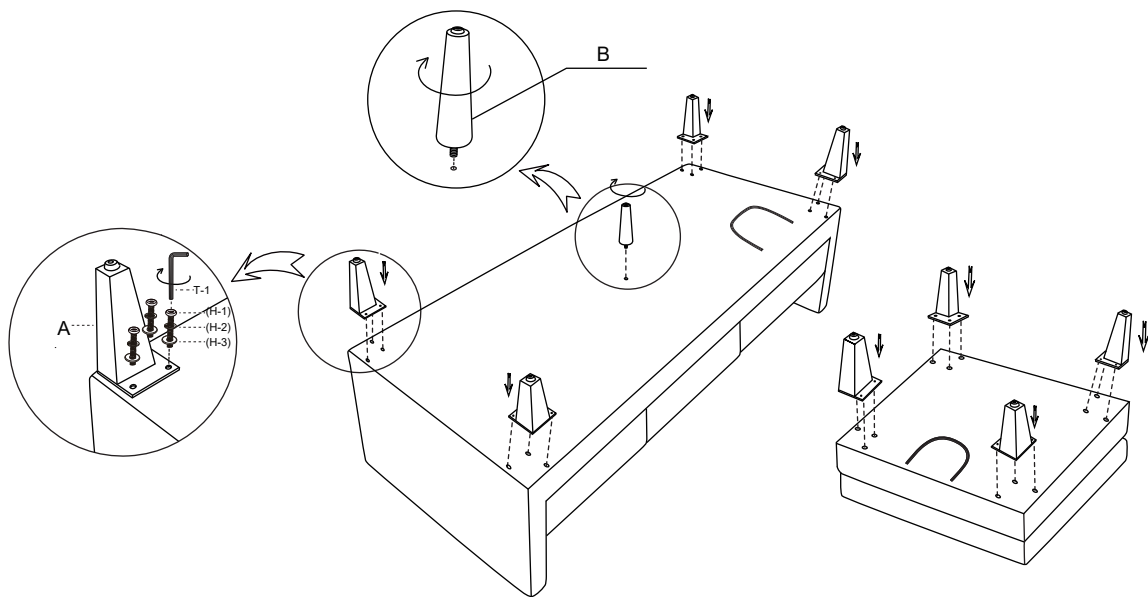

For both the sofa and ottoman assembly, align the mounting plate holes on legs (A) with the corresponding holes at each corner of the sofa and ottoman. Secure the Legs (A) using Allen Bolts (H-1), Spring Washers (H-2) and Flat Washers (H-3), stacking the hardware in the order shown. Engage all bolts first, then fully tighten using Allen Key (T-1). Next, remove the protective bolt cover on the Mid Leg (B) and secure it to the middle of sofa assembly by turning clockwise until snug.

Assembly Steps

Step 3

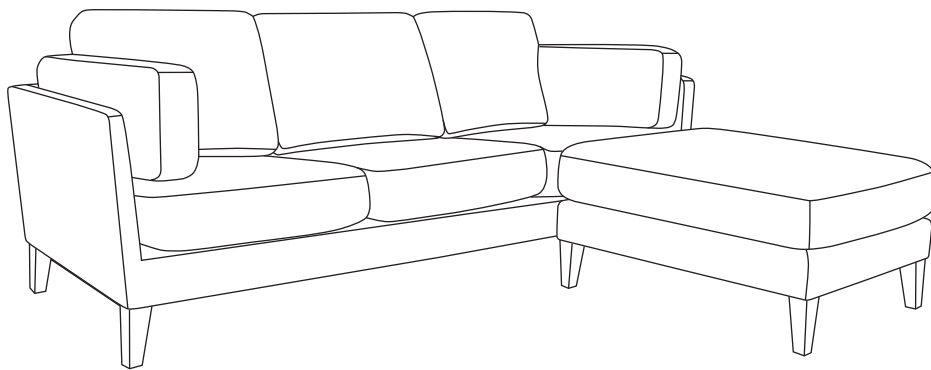

The Sofa is now complete and the product is ready for use.

**ENSURE ALL BOLTS ARE FULLY TIGHTENED EVERY 3 MONTHS
TO ENSURE STABILITY.**

Care & Maintenance



- Do not put hot items directly on furniture surface.



- Do not clean furniture with harsh cleansers or polish.



- Do not place furniture in direct sunlight.



- Do not place furniture near heating or cooling vents.



- Do not write on furniture without a padded barrier to protect the surface.



- Do not place furniture outside. For indoor use only.



- All products sold at world market are not for commercial use and are intended for residential use only.



- Dust and pick-up spills using a clean, non-colored, lint-free cloth.

WORLD MARKET LIMITED ONE-YEAR WARRANTY – Indoor Furniture

For your customer satisfaction, this product carries a LIMITED ONE-YEAR WARRANTY from the date of purchase. This limited warranty only applies to World Market brand furniture, and not to other furniture brands sold on World Market's website.

Where applicable, the limited warranty provides coverage for:

1. **Manufacturing, Material and Workmanship Defects:** Includes defects related to core frame/structure substrates (wood and metal); cracking, splitting, or complete breakage of hardwood, plywood or medium density fiberboard (MDF); cracking, splitting or lifting of wood veneer or laminated top surfaces caused by process failure; broken welds or improperly coated metal frame components (powder coating or painted); fabric or leather material defects including tears, misprints, fraying, crease marks, skip stitches or open seams; support webbing material and sinuous spring defects or damage, including method of attachment to frame; and other component failures that are a direct result of manufacturing or workmanship defects.
2. **Cushions & Cushions with Enclosed Steel Pocket Coils:** Failed or ruptured steel pocket coils enclosed inside of seat cushions, or loss of resiliency from a material breakdown of foam or fiber filling, which should not be confused with softening or settling during normal use.
3. **Leather:** Splitting or cracking of leather material. NOTE: The warranty does NOT cover natural hide markings, variations in the leather color or grain due to the authentic natural properties of processed cowhide leather.
4. **Bonded Leather or Bi-cast Leather:** Separation of the polyurethane coating, peeling or cracking of the inner layer or at the bonded seam edges (bi-cast straps).
5. **Furniture Components (Hardware & Mechanisms):** Includes defects to pre-installed components or hardware provided to the customer for assembly such as office chair hydraulic lifts, lift mechanisms, metal bases and casters, swivel plate mechanisms; for drawers, metal glides, handles/knobs; for doors, hinges, magnetic latches; and other components such as bent or stripped threaded leg posts and adjustable levelers. For missing, damaged, corroded, or misplaced hardware components such as bolts or washers, please contact Customer Service at: 877-967-5362.

This LIMITED ONE-YEAR WARRANTY does NOT cover:

1. Damage due to mishandling during transportation from store or transportation without original protective packaging.
2. Abuse, negligence (product misuse) or wear and tear that may result in or from:
 - a. **Wood & Veneer:** Mishandling, exposure to moisture, peeling or discoloration caused by exposure to moisture or excessive sunlight, heat; splintered, dented or nicked panels, legs or component edges or paint/finish blemishes; or treatment with corrosive chemicals (dyes, inks, paints or harsh cleaning products).
 - b. **Fabric & Leather (Including Bonded or Bi-Cast Leathers):** cuts, punctures, tears, burns, pet damage, or treatment with corrosive chemicals (dyes, inks, paints or harsh cleaning products), exposure to direct sunlight, fire, high heat, water, or any bright light source (natural or artificial) that may cause splitting, peeling or flaking with time.
 - c. **Foam (Cushions):** Flattening, relaxing or settling/softening of foam components that comes with normal use.
 - d. **Hardware Components:** improper installation or misuse/substitution of hardware components not defined in the Assembly Instructions for the product (if applicable)
3. Damage due to environmental exposure to direct sunlight, fire, high heat, water or extreme humidity, any bright light source (natural or artificial), or any environment that the product is not intended for.
4. This warranty is applicable for indoor furniture products purchased for residential use only.

For additional information on returns, please visit: <https://www.worldmarket.com/category/customer-service/returns.do>

All products sold at World Market are NOT FOR COMMERCIAL USE and are intended for residential use only. Products purchased for commercial use will VOID all warranty provisions as listed above.

Any claims under this LIMITED ONE-YEAR WARRANTY are valid and applicable only as to the original purchaser and must be accompanied by proof of purchase. Warranty claims should be submitted to a World Market store or through World Market Customer Service Call Center, Toll Free at 877-967-5362.

For valid warranty claims, World Market will repair or replace the product, or offer a full or partial credit, in the sole discretion of World Market. This LIMITED ONE-YEAR WARRANTY gives you specific legal rights and you may also have other rights which vary from state to state.

(INDOOR FURNITURE 1LW_v1.5_051122)